

MAX. ENGINE POWER: 9.0 kW (12.0 hp)    MAX. DIG DEPTH: 1.69 metres (5ft 6in)

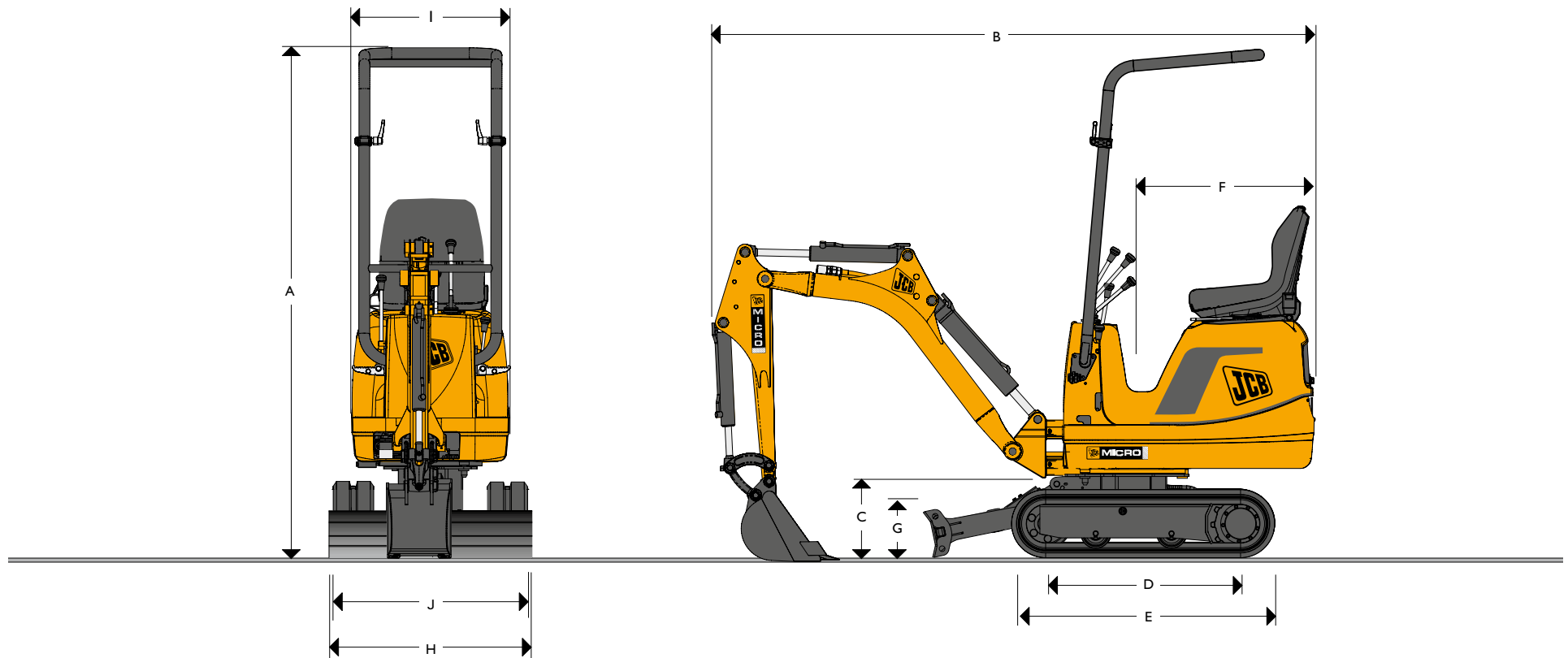

## PERFORMANCE AND DIMENSIONS

Machine model		8008
A Overall height (trans pos)	mm (ft-in)	2310 (7-7)
B Overall length (trans pos)	mm (ft-in)	2682 (8-9)
C Kingpost clearance	mm (ft-in)	356 (1-2)
D Sprocket idler centres	mm (ft-in)	865 (2-8)
E Undercarriage length	mm (ft-in)	1165 (3-10)
F Tailswing	mm (ft-in)	800 (2-7)
G Dozer height	mm (in)	200 (0-8)
H Dozer width (retracted)	mm (ft-in)	700 (2-4)
Dozer width (extended)	mm (ft-in)	900 (2-11)

Machine model		8008
I Superstructure width	mm (ft-in)	695 (2-3)
J Width over tracks (retracted)	mm (ft-in)	700 (2-4)
Width over tracks (extended)	mm (ft-in)	865 (2-10)
Max bucket tearout	kN (lbf)	9.3 (2091)
Max dipper tearout	kN (lbf)	4.6 (1034)
Travel speeds kph 1st Gear	kph (mph)	1.8 (1.1)
Drawbar pull	kN (lbf)	7.75 (1742)
Slew speed	rpm	7

**ENGINE**

Machine model		8008
Model		403D-07
Rated power – ISO 14396 (SAE J1995 – Gross)		
Gross power	kW (HP)	9.0 (12.0)
Gross torque	Nm (lbf ft)	46 @ 1800 (33.9)
Displacement	cc	762
Gradeability	degrees	35
Starter motor	kW (HP)	1.2 (1.6)
Alternator	Amp	15

**UNDERCARRIAGE**

Machine model		8008
No of bottom rollers		2
Track width	mm (in)	180 (7)
Ground bearing pressure	Kg/cm <sup>2</sup> (psi)	0.23 (3.3)
Ground clearance	mm (in)	130 (5.0)
Track tensioning		Grease

**HYDRAULICS**

Machine model		8008
Pump		2 section gear
Nominal output	Lpm (gpm)	11.2 x 2 (2.5 x 2)
Excavator/track main relief	Bar (psi)	170 (2465)
Slew main relief	Bar (psi)	90 (1305)
Auxiliary hydraulic flow	Ltr (gal)	22.4 (5.0)
Hydraulic motors		Piston

**SERVICE CAPACITIES**

Machine model		8008
Water system capacity	Ltr (Gal)	2.6 (0.6)
Fuel tank capacity	Ltr (Gal)	11.5 (2.5)
Engine oil capacity	Ltr (Gal)	3.0 (0.7)
Hydraulic system capacity	Ltr (Gal)	21 (4.6)
Hydraulic tank capacity	Ltr (Gal)	16 (3.5)

**MACHINE WEIGHTS**

Machine model		8008
Operating weight*	kg (lb)	950 (2094)
Transport weight with 2 post TOPS	kg (lb)	875 (1929)
2 post TOPS weight	kg (lb)	35 (77)

**STANDARD AND OPTIONAL EQUIPMENT**

Machine model		8008
TOPS certified frame		0†
Front handrail only		0
Full audible systems		S
Toolkit		0
Slew travel lock		S
Rubber tracks		S
Extending undercarriage		S
ISO pattern controls		S
Vinyl static seat		S
880mm dipper		S
Boom offset		S
Dozer blade		S
Double acting pipework		0
Boom worklight		0
General purpose buckets:		
160mm (6") to 410mm (16")		0
Ditching / grading buckets:		
700mm (28")		0
JCB Breaker: HM60		-
Earth drills		0

† Please note the TOPS frame may be a legal requirement in your territory.

\* Operating weight to ISO 6016 including 2 post TOPS frame, rubber tracks, standard dipper, standard dozer, 300mm bucket,

full tanks and a 75kg operator.

S = Standard 0 = Optional

## BOOM SWING RADIUS

Machine model		8008
K Boom swing right	degrees	70
L Boom swing left	degrees	70

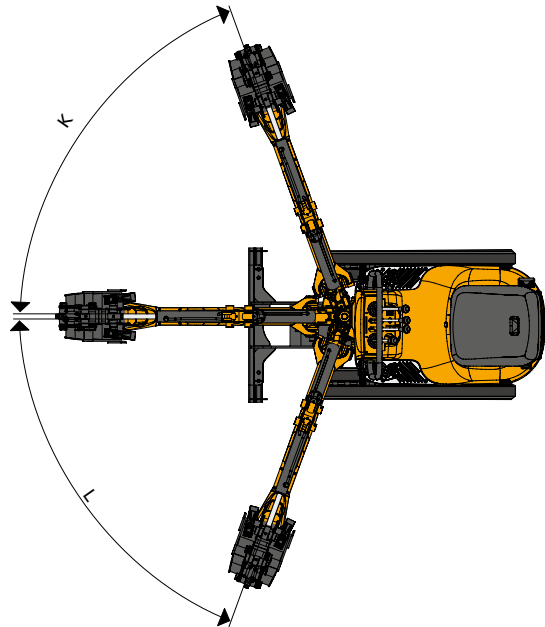

## WORKING RANGE

Machine model		8008
M Max dig height	mm (ft-in)	2840 (9-4)
N Max dump height	mm (ft-in)	1980 (6-6)
O Max vertical dig depth	mm (ft-in)	1480 (4-10)
P Max dig depth-dozer up	mm (ft-in)	1690 (5-6)
Q Max ground level reach	mm (ft-in)	3110 (12-2)
Bucket rotation	degrees	191°
R Dozer cut above ground	mm (in)	200 (0-8)
S Dozer cut below ground	mm (in)	110 (0-4)
T Min. slew radius	mm (ft-in)	1240 (4-1)

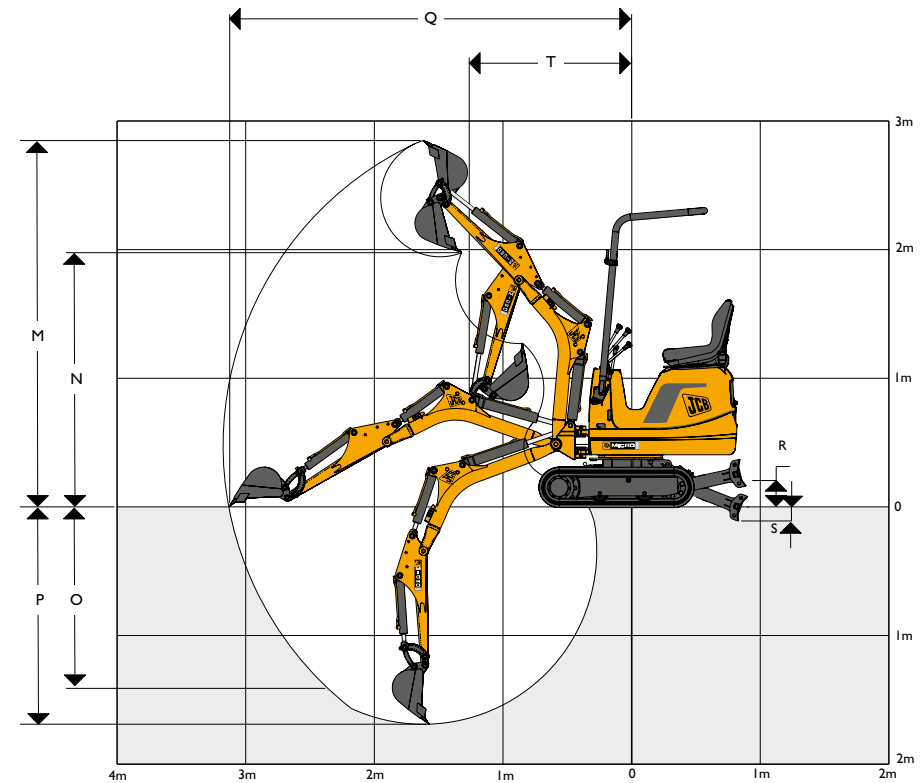

## A GLOBAL COMMITMENT TO QUALITY

JCB's total commitment to its products and customers has helped it grow from a one-man business into Britain's largest privately owned manufacturer of backhoe loaders, crawler excavators, wheeled excavators, telescopic handlers, wheeled loaders, dump trucks, rough terrain fork lifts, industrial fork lifts, mini/midi excavators, skid steer loaders, tractors and compaction equipment.

By making constant and massive investments in the latest production technology, the JCB factories have become some of the most advanced in the world.

By leading the field in innovative research and design, extensive testing and stringent quality control, JCB machines have become renowned all over the world for performance, value and reliability.

And with a global sales and service network of more than 650 dealers and agents, we aim to deliver the best customer support in the industry.

Through setting the standards by which others are judged, JCB has become one of the world's most impressive success stories.

