



JCB TRACKED EXCAVATOR | JS 190 NLC/LC



MAX. OPERATING WEIGHT

20003 kg (44099 lb)

NETT ENGINE POWER

124 kW (166 hp)

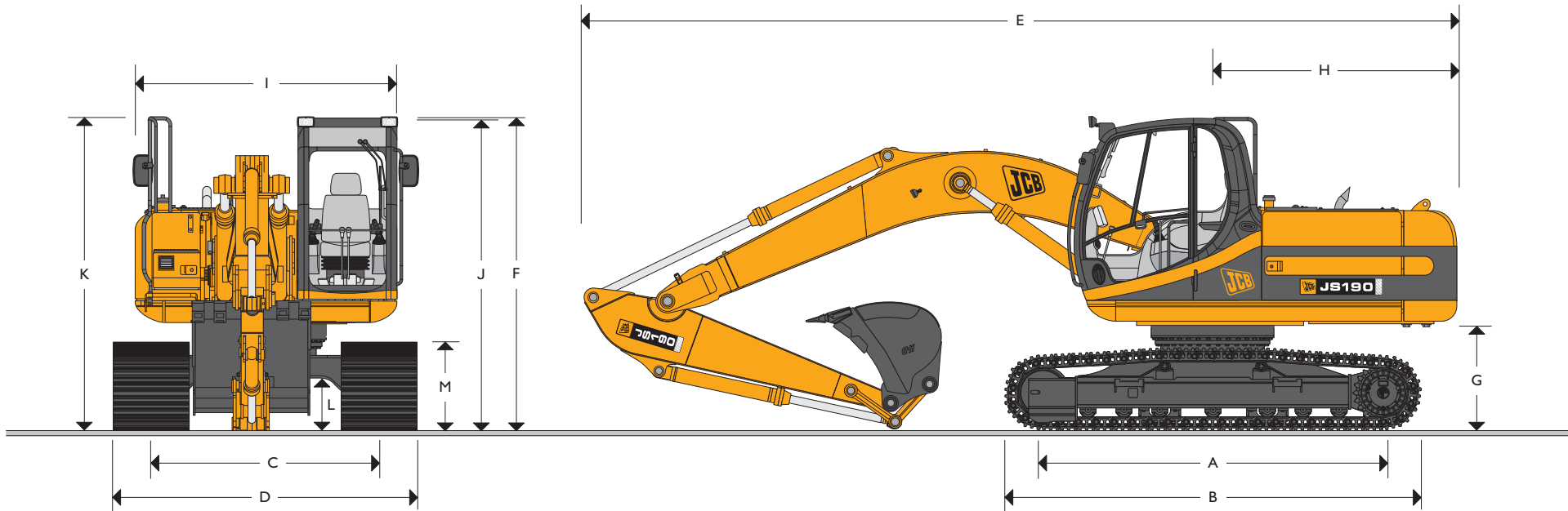

STATIC DIMENSIONS – JS 190 NLC/LC MONOBOOM

Dimensions in millimetres (ft-in)	NLC	LC	
A Track length on ground	3370 (11-1)	3370 (11-1)	
B Undercarriage overall length	4170 (13-8)	4170 (13-8)	
C Track gauge	1990 (6-6)	2200 (7-2)	
D Width over tracks (500mm trackshoes)	2490 (8-2)	–	
D Width over tracks (600mm trackshoes)	2590 (8-6)	2800 (9-2)	
D Width over tracks (700mm trackshoes)	2690 (8-10)	2900 (9-6)	
D Width over tracks (800mm trackshoes)	–	3000 (9-10)	
Dipper lengths	2.25m (7ft 5in)	2.7m (8ft 10in)	3.05m (10ft 0in)*
E Transport length with Monoboom	8366 (27-5)	8326 (27-4)	8415 (27-7)
F Transport height with Monoboom	3014 (9-10)	3014 (9-10)	3014 (9-10)

Dimensions in millimetres (ft-in)	
G Counterweight clearance	1072 (3-6)
H Tail swing radius	2338 (7-8)
I Width of superstructure	2740 (8-11)
J Height over cab	2987 (9-10)
K Height over grab rail	3014 (9-10)
L Ground clearance	486 (1-7)
M Track height	885 (2-11)

*Machine in transport position



JCB TRACKED EXCAVATOR | JS 190 NLC/LC



MAX. OPERATING WEIGHT

20488 kg (45168 lb)

NETT ENGINE POWER

124 kW (166 hp)

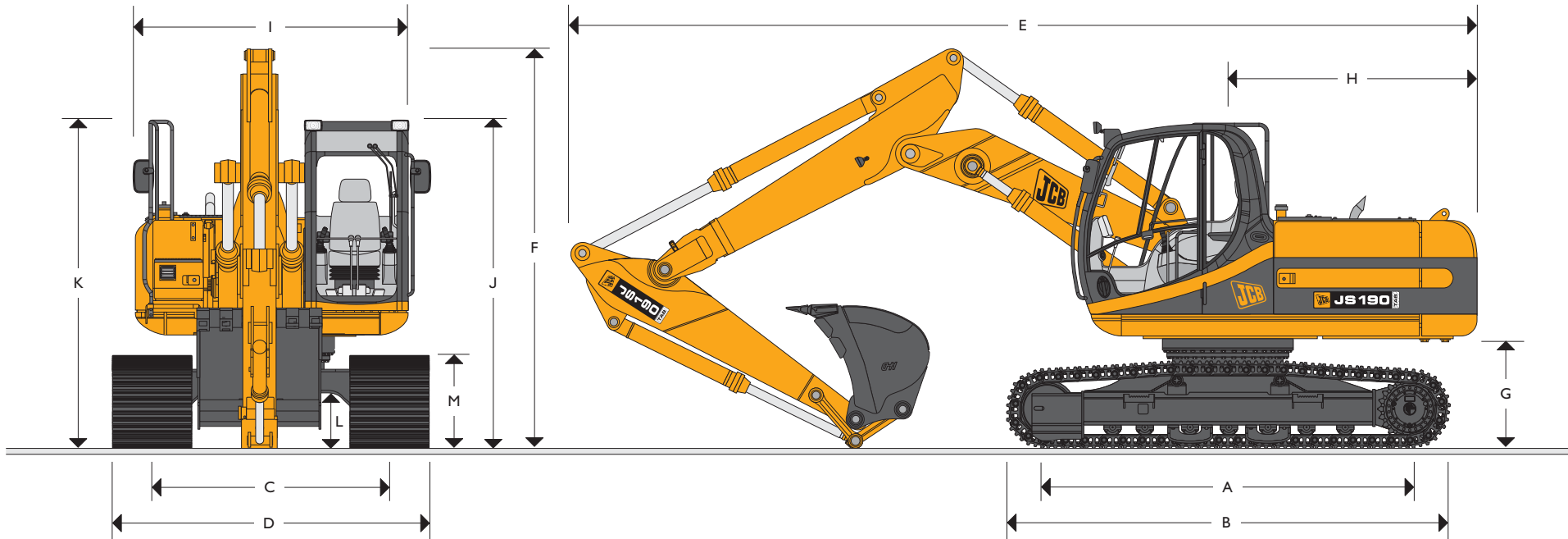

STATIC DIMENSIONS – JS 190 NLC/LC T.A.B.

Dimensions in millimetres (ft-in)	NLC	LC	
A Track length on ground	3370 (11-1)	3370 (11-1)	
B Undercarriage overall length	4170 (13-8)	4170 (13-8)	
C Track gauge	1990 (6-6)	2200 (7-2)	
D Width over tracks (500mm trackshoes)	2490 (8-2)	–	
D Width over tracks (600mm trackshoes)	2590 (8-6)	2800 (9-2)	
D Width over tracks (700mm trackshoes)	2690 (8-10)	2900 (9-6)	
D Width over tracks (800mm trackshoes)	–	3000 (9-10)	
Dipper lengths	2.25m (7ft 5in)	2.7m (8ft 10in)	3.05m (10ft 0in)*
E Transport length with TA Boom	8652 (28-5)	8674 (28-5)	8644 (28-4)
F Transport height with TA Boom	2876 (9-5)	2760 (9-1)	2823 (9-3)

Dimensions in millimetres (ft-in)	
G Counterweight clearance	1072 (3-6)
H Tail swing radius	2338 (7-8)
I Width of superstructure	2740 (8-11)
J Height over cab	2987 (9-10)
K Height over grab rail	3014 (9-10)
L Ground clearance	486 (1-7)
M Track height	885 (2-11)

*Machine in transport position



JCB TRACKED EXCAVATOR | JS I90 NLC/LC



ENGINE

Model	Isuzu 4HKIX European Tier III emission compliant.
Type	Watercooled, 4-stroke, 4-cylinder in-line, direct injection, turbocharged diesel.
Nett power (ISO 3046-1NF)	124kW (166hp) at 1800rpm.
Piston Displacement	5.193 litres.
Injection	Electrical governor.
Air Filtration	Dry element with secondary safety element and in cab warning indicator.
Cooling	Water cooler via large capacity radiator.
Starting system	24 volt – 4.5kW.
Batteries	2 x 12 volt Heavy Duty.
Alternator	24 volt 40 amp.
Refuelling pump	Electric type.

SWING SYSTEM

Swing motor	Axial piston type.
Swing brake	Hydraulic braking plus automatic spring applied disc type parking brake.
Final drive	Planetary reduction.
Swing speed	10 rpm.
Swing gear	Large diameter; internally toothed fully sealed grease bath lubricated.
Swing lock	Multi position switchable brake.

UNDERCARRIAGE

Carriage options	NLC-Narrow and LC-Long Carriage.
Construction	Fully welded, "X" frame type with central bellyguarding and track motor guards. Sloping sidemembers with dirt relief holes under top rollers.
Recovery point	Front and rear.
Track type	Sealed and greased.
Track shoe options	NLC – 500mm (20in), 600mm (24in), 700mm (28in). LC – 600mm (24in), 700mm (28in), 800mm (31.5in).
Upper & lower rollers	Heat treated, sealed and lubricated.
Track adjustment	Grease cylinder type.
Track idler	Sealed and lubricated, with spring cushioned recoil.
NLC & LC	
No. of track guides	2 per side
No. of lower rollers	7 per side
No. of upper rollers	2 per side
No. of track shoes	46 per side

HYDRAULIC SYSTEM

A variable flow load sensing system with flow on demand, variable power output and servo operated, multi-function open centre control. Machine auto warm up standard – maximises performance in cold conditions.

Pumps

Main pumps	2 variable displacement axial piston type.
Maximum flow	2 x 140 L/min (2 x 30.7 UK GPM).
Servo pump	Gear type.
Maximum flow	17.5 L/min (3.84 UK GPM).

Control valve

A combined ten spool control valve with auxiliary service spool as standard. When required twin pump flow is combined to boom, dipper and bucket services for greater speed and efficiency.

Relief valve settings

Boom/Arm/Bucket	314 bar (4610lbf/sq.in)
With power boost	343 bar (4975lbf/sq.in)
Swing circuit	279 bar (4045lbf/sq.in)
Travel circuit	343 bar (4975lbf/sq.in)
Pilot control	40 bar (569lbf/sq.in)

A separate Cushion Control valve in the servo system provides cushioning of the boom and dipper spools selection and quick warm-up of the servo system.

Hydraulic cylinders

Double acting type, with bolt-up end caps and hardened steel bearing bushes. End cushioning is fitted as standard on boom, dipper and bucket rams.

Optional hose burst check valves available for boom and dipper rams.

Filtration

The hydraulic components are protected by the highest standard of filtration to ensure long hydraulic fluid and component life.

In tank	150 micron, suction strainer.
Main return line	10 micron, fibreform element.
Plexus Bypass line	1.5 micron, paper element.
Pilot line	10 micron, paper element.
Hydraulic hammer return	10 micron, reinforced microform element.

Cooling

Worldwide cooling is provided as part of a single face cooling pack, in conjunction with the engine water cooler.

TRACK DRIVE

Type	Fully hydrostatic, three speed with autoshift between high and medium speed.
Travel motors	Variable swash axial piston type, fully guarded within undercarriage frame.
Final drive	Planetary reduction, bolt-on sprockets.
Service brake	Hydraulic counter balance valve to prevent overspeeding on gradients.
Park brake	Disc type, spring applied, automatic hydraulic release.
Gradeability	70% (35 deg) continuous.
Travel speed	High – 5.5 km/h (3.4 mph). Mid – 3.4 km/h (2.1 mph). Low – 2.5 km/h (1.5 mph).
Tractive effort	144kN (14684kgf, 32372lbf).



JCB TRACKED EXCAVATOR | JS I90 NLC/LC



EXCAVATOR END – MONOBOOM

Monoboom available along with a choice of dipper lengths to suit the requirements of reach, dig-depth, loadover height, tearouts and site versatility. Reserve strength is built into the fully welded structures for hydraulic hammer and other arduous operations. Fabricated bucket tipping links are provided with a choice of lift points. Strong, durable construction, large cross sections and multi plate fabrications to withstand high stress applications. The 5.15m (16ft 11 in) boom is designed to ensure the optimum digging envelope when matched with the three dipper lengths. Low maintenance bronze alloy bushes with graphite plugs are fitted to boom base and boom to dipper pivots resulting in 1000 hour greasing intervals at these points.

EXCAVATOR END – T.A.B.

Triple Articulated Boom (T.A.B.) with a choice of dipper lengths to suit the requirements of reach, dig-depth, loadover height, tearouts and site versatility. Reserve strength is built into the fully welded structures for hydraulic hammer and other arduous operations. Fabricated bucket tipping links are provided with a choice of lift points.

CAB

Excellent digging, loading and positioning visibility results from the careful design of front, side and roof lights. All screens are tinted to improve in cab conditions. Fully opening front screen is very smooth to operate and as the lower screen is stored within the top screen frame it makes complete front screen opening easy, fast and convenient. Fresh air ventilation available from opening door window, opening slot in front screen and fully opening front screen. Parallelogram wash wiper for upper screen ensuring good wiped area for maximum visibility. Wiper motor is fitted in the left hand side of the roof screen so as not to affect bucket visibility when loading. Optional lower screen wiper available. Fresh air ventilation and heater with windscreen demister. Infinitely variable blower speed, temperature and recirculation control. Optional climate control. Fully adjustable deluxe suspension seat with arm rest adjustment and backrest recline. Optional radio with digital tuner fitted into the roof lining for maximum protection. Conveniently placed radio mute button incorporated into lower console. 12v power point and mobile phone holder built into the right hand console. Courtesy light can be operated from ground level and is illuminated for five minutes or until switched off improving operator access at night. Cab mounted roller blind protects operator from suns' glare through front or top screens.

AMS – ADVANCED MANAGEMENT SYSTEM

Four selectable working modes link the operators control movements with the engine and hydraulic systems to maximise productivity and efficiency.

A (Auto)

Up to 100% power and 100% flow. Gives variable power and speed depending on the operator's input, matching the demand for output and efficiency to the job. Power boost is automatically activated in this mode should hard conditions be encountered. Auto idle cuts in after a period of inactivity (between 5 and 30 seconds as set by the operator)

E (Economy)

80% power. 95% of hydraulic flow maximises economy while maintaining excellent output.

P (Precision)

55% power. 90% of hydraulic flow for fine control of grading operations.

L (Lifting)

55% power. 63% of hydraulic flow with permanent power boost for maximum lifting power and control.

The Auto mode allows the AMS processor to select the optimum operational performance to match the demands of the job while the three alternative modes give precise matching of application when specific tasks are undertaken.

The adjustable position monitor mounted on the front right hand pillar of the cab gives the operator a constant read out of mode, tracking range, operating temperature and a host of other information, while retaining excellent visibility of the monitor and the job being carried out.

The required flow for hammer applications can be set and stored in the AMS memory and is automatically activated whenever the hammer pedal is depressed.

A maintenance indicator warns of imminent service needs, and all servicing and basic checks can be carried out using only the in cab display.

CONTROLS

Excavator

Tracks

All servo lever operated to ISO control pattern, independently adjustable to the seat.

Individually servo operated by foot pedal or hand lever.

Speed selection via joystick button.

Via servo operated foot pedal.

Auxiliary

Control isolation

Via gate lock lever at cab entrance or panel switch.

Engine speed

Dial type throttle control plus servo lever mounted one-touch idle control or separate selectable auto-idle with adjustable time delay using AMS.

Engine stop

Ignition key operated and separate shut-down button.

Horn

Operated via servo lever mounted button.



JCB TRACKED EXCAVATOR | JS I90 NLC/LC



SERVICE CAPACITIES

	Litres	UK Gal
Fuel tank	253	55.6
Engine coolant	16.4	3.8
Engine oil	13.2	2.9
Swing reduction gear	6	1.3
Track reduction gear (each side)	4.4	0.97
Hydraulic system	142.0	31.2
Hydraulic tank	73.0	16.1

WEIGHTS AND GROUND BEARING PRESSURES

JSI90NLC – Machine equipped with 5.15m Monoboomb, 3.05m Dipper, 0.9m³ Bucket, operator and full fuel tank.

Shoe Width	Operating Weight	Bearing Pressure
500mm (20in.)	19418kg (42809lb)	0.51kg/sq. cm. (7.3lb/sq. in.)
600mm (24in.)	19544kg (43087lb)	0.43kg/sq. cm. (6.1lb/sq. in.)

JSI90LC – Machine equipped with 5.15m Monoboomb, 3.05m Dipper, 0.9m³ Bucket, operator and full fuel tank.

Shoe Width	Operating Weight	Bearing Pressure
600mm (24in.)	19628kg (43272lb)	0.43kg/sq. cm. (6.1lb/sq. in.)
700mm (28in.)	19983kg (44055lb)	0.38kg/sq. cm. (5.4lb/sq. in.)

JSI90NLC T.A.B. – Machine equipped with 5.35m T.A.B. boom, 3.05m Dipper, 0.9m³ Bucket, operator and full fuel tank.

Shoe Width	Operating Weight	Bearing Pressure
500mm (20in.)	19903kg (43879lb)	0.57kg/sq. cm. (8.11lb/sq. in.)
600mm (24in.)	20029kg (44156lb)	0.47kg/sq. cm. (6.68lb/sq. in.)

JSI90LC T.A.B. – Machine equipped with 5.35m T.A.B. boom, 3.05m Dipper, 0.9m³ Bucket, operator and full fuel tank.

Shoe Width	Operating Weight	Bearing Pressure
600mm (24in.)	20113kg (44342lb)	0.48kg/sq. cm. (6.83lb/sq. in.)
700mm (28in.)	20468kg (45124lb)	0.42kg/sq. cm. (5.97lb/sq. in.)

STANDARD EXCAVATING BUCKETS

All buckets are JCB – Escó type fully welded steel, with sealed, hardened steel pivot pins and replaceable wear parts.

Max Width	Capacity (SAE heaped)	Weight
600mm (24in.)	0.35cu.m (0.46cu.yd)	426kg (937lb)
750mm (30in.)	0.49cu.m (0.64cu.yd)	480kg (1056lb)
900mm (36in.)	0.62cu.m (0.81cu.yd)	525kg (1155lb)
1000mm (40in.)	0.72cu.m (0.94cu.yd)	564kg (1240lb)
1200mm (48in.)	0.90cu.m (1.18cu.yd)	633kg (1392lb)

STANDARD / OPTIONAL EQUIPMENT

Standard Equipment: Engine fan guard; Cold start pre-heat; Auto engine warm up; Double element air cleaner; Heavy duty alternator; Electrics isolator; Heavy duty batteries; Cab & engine soundproofing; Cab heater & screen demister; Tinted glass; Interior light; Coat hook; Cigarette lighter; Ashtray; Operator's storage shelf; Removable floor mat; Windscreen wash/wipe; Plug-in power socket; Automatic power boost; Auto-idle; One-touch engine speed control; Hydraulic cushion control; Plexus hydraulic oil filtration; HSP pressure test points; Auxiliary pipework mounting brackets; Work lights – boom & mainframe mounted; Undercarriage belly guarding; Upper structure under covers; Swing system cover; External mirrors; Handrail & non slip walk ways; Quick connect engine oil drain pipe; Front screen blind; Quick connect fuel tank drain pipe; Hinged engine under cover; Remote filter system.

Optional Equipment: Hose burst check valves & overload warning system; Tipping link mounted lift points; General purpose buckets; Ditch/grading buckets; Quickhitch buckets; Hydraulic hammers; Auxiliary pipework (full and low flow); Climate control; Cab mounted & rear work lights; Rotating beacon; Rain guard; Biodegradable oil; Air suspension seat with heated pad and lumbar support adjustment; Electric refuelling pump; Track guides; Lower screen wiper; Radio; High and low temperature hydraulic oil option.



JCB TRACKED EXCAVATOR | JS 190 NLC/LC



WORKING RANGE – JS190 NLC/LC MONOBOOM

Boom length: 5.15m (16ft 11in)		
Dipper length:		2.25m (7ft 5in)
A	Maximum digging reach	mm (ft-in) 8514 (27-11)
B	Maximum digging reach (on ground)	mm (ft-in) 8368 (27-5)
C	Maximum digging depth	mm (ft-in) 5799 (19-0)
D	Maximum digging height	mm (ft-in) 9398 (30-9)
E	Maximum dumping height	mm (ft-in) 7048 (23-1)
F	Maximum vertical wall cut depth	mm (ft-in) 5229 (17-2)
G	Minimum swing radius	mm (ft-in) 3000 (9-10)
	Bucket rotation	182°
	Maximum dipper tearout (ISO 6015)	kgf (lbf) 8754 (19259)
	Maximum bucket tearout (ISO 6015)	kgf (lbf) 11839 (26104)
Dipper length: 2.70m (8ft 10in)		
A	Maximum digging reach	mm (ft-in) 8908 (29-3)
B	Maximum digging reach (on ground)	mm (ft-in) 8769 (28-9)
C	Maximum digging depth	mm (ft-in) 6252 (20-6)
D	Maximum digging height	mm (ft-in) 9663 (31-8)
E	Maximum dumping height	mm (ft-in) 7321 (24-0)
F	Maximum vertical wall cut depth	mm (ft-in) 5682 (18-8)
G	Minimum swing radius	mm (ft-in) 3000 (9-10)
	Bucket rotation	182°
	Maximum dipper tearout (ISO 6015)	kgf (lbf) 7619 (16764)
	Maximum bucket tearout (ISO 6015)	kgf (lbf) 11839 (26104)
Dipper length: 3.05m (10ft 0in)		
A	Maximum digging reach	mm (ft-in) 9223 (30-7)
B	Maximum digging reach (on ground)	mm (ft-in) 9088 (29-10)
C	Maximum digging depth	mm (ft-in) 6598 (21-8)
D	Maximum digging height	mm (ft-in) 9888 (32-5)
E	Maximum dumping height	mm (ft-in) 7543 (24-8)
F	Maximum vertical wall cut depth	mm (ft-in) 6028 (19-9)
G	Minimum swing radius	mm (ft-in) 3000 (9-10)
	Bucket rotation	182°
	Maximum dipper tearout (ISO 5016)	kgf (lbf) 7003 (15439)
	Maximum bucket tearout (ISO 5016)	kgf (lbf) 11839 (26104)

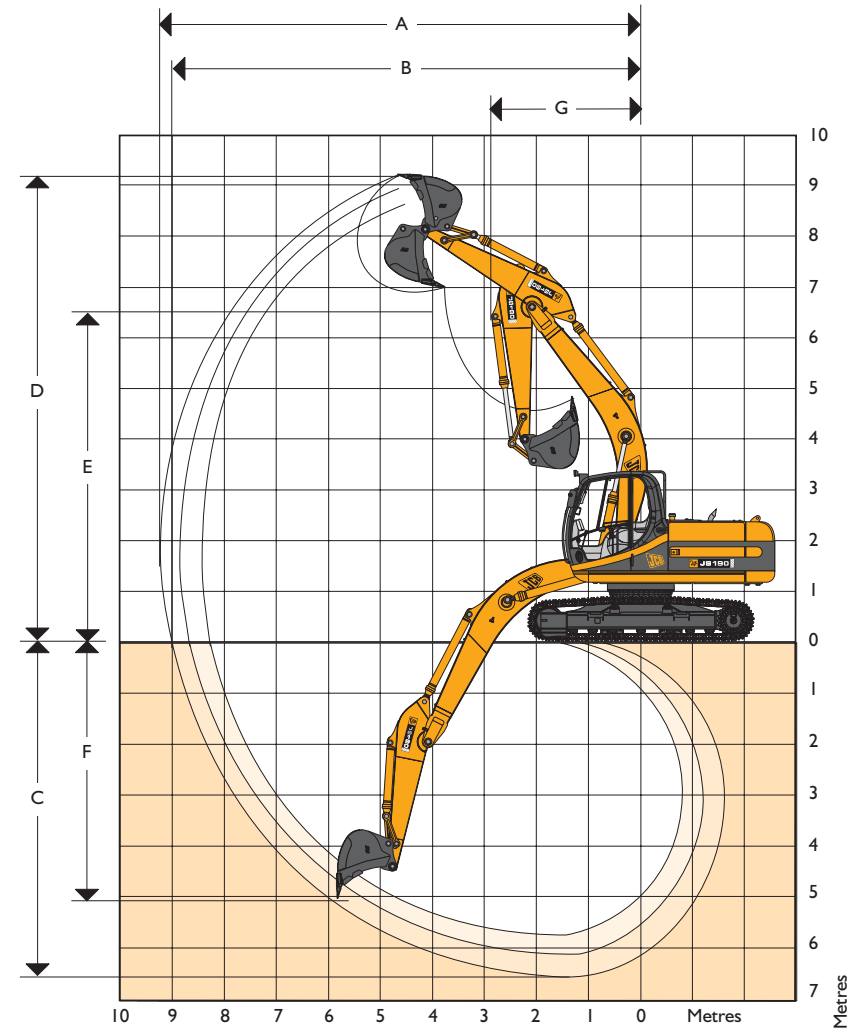



JCB TRACKED EXCAVATOR | JS I90 NLC/LC



WORKING RANGE – JS I90 NLC/LC T.A.B.

T.A.Boom length: 5.35m (16ft 11in)		
Dipper length:		2.25m (7ft 5in)
A	Maximum digging reach	mm (ft-in) 8831 (29-0)
B	Maximum digging reach (on ground)	mm (ft-in) 8652 (28-5)
C	Maximum digging depth	mm (ft-in) 5354 (17-7)
D	Maximum digging height	mm (ft-in) 10248 (33-7)
E	Maximum dumping height	mm (ft-in) 8000 (26-3)
F	Maximum vertical wall cut depth	mm (ft-in) 4232 (13-10)
G	Minimum swing radius	mm (ft-in) 2170 (7-1)
	Bucket rotation	182°
	Maximum dipper tearout (ISO 6015)	kgf (lbf) 8754 (19259)
	Maximum bucket tearout (ISO 6015)	kgf (lbf) 11839 (26104)
<hr/>		
Dipper length:		2.70m (8ft 10in)
A	Maximum digging reach	mm (ft-in) 9260 (30-5)
B	Maximum digging reach (on ground)	mm (ft-in) 9094 (2-10)
C	Maximum digging depth	mm (ft-in) 5786 (18-11)
D	Maximum digging height	mm (ft-in) 10674 (35-0)
E	Maximum dumping height	mm (ft-in) 8444 (27-8)
F	Maximum vertical wall cut depth	mm (ft-in) 4699 (15-5)
G	Minimum swing radius	mm (ft-in) 2227 (7-3)
	Bucket rotation	182°
	Maximum dipper tearout (ISO 6015)	kgf (lbf) 7619 (16764)
	Maximum bucket tearout (ISO 6015)	kgf (lbf) 11839 (26104)
<hr/>		
Dipper length:		3.05m (10ft 0in)
A	Maximum digging reach	mm (ft-in) 9592 (31-6)
B	Maximum digging reach (on ground)	mm (ft-in) 9463 (31-1)
C	Maximum digging depth	mm (ft-in) 6108 (20-0)
D	Maximum digging height	mm (ft-in) 10822 (35-6)
E	Maximum dumping height	mm (ft-in) 8672 (28-5)
F	Maximum vertical wall cut depth	mm (ft-in) 5211 (17-1)
G	Minimum swing radius	mm (ft-in) 2587 (8-6)
	Bucket rotation	182°
	Maximum dipper tearout (ISO 5016)	kgf (lbf) 7003 (15439)
	Maximum bucket tearout (ISO 5016)	kgf (lbf) 11839 (26104)

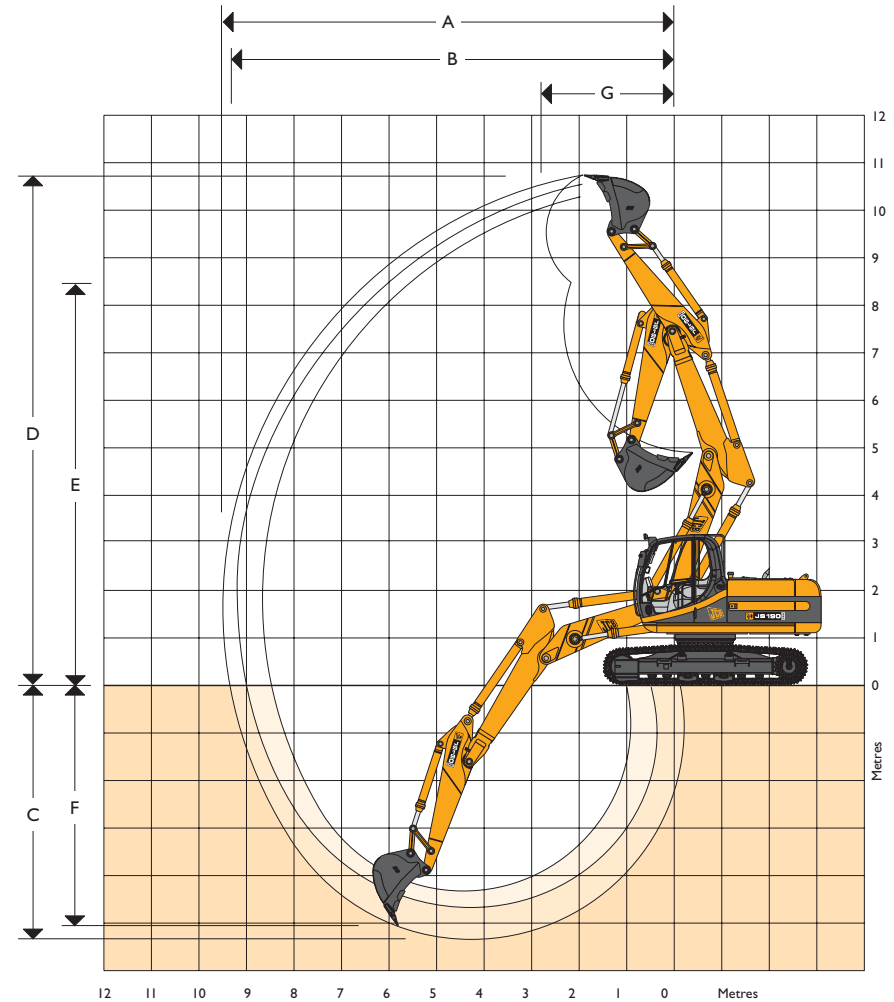



JCB TRACKED EXCAVATOR | JS I90 NLC/LC



LIFT CAPACITIES – Dipper Length: 2.25m, 5.15m Monoboom, Tracks: 500mm, No bucket.

JS I90 NLC MONO

Reach	1.5m (4ft 11in)		3m (9ft 10in)		4.5m (14ft 9in)		6m (19ft 8in)		7.5m (24ft 7in)		Capacity at Max Reach		
											kg	kg	mm
Load Point Ht.	kg	kg	kg	kg	kg	kg	kg	kg	kg	kg	kg	kg	mm
7.5m (24.7ft)											3900*	3900*	4484
6.0m (19.8ft)							4050*	3620			3350*	3350*	5956
4.5m (14.9ft)					5520*	5480	5000*	3560			3200*	2930	6795
3.0m (9.10ft)					6880*	5160	5530*	3440			3230*	2610	7230
1.5m (4.11ft)					8190*	4860	5650	3300			3420*	2510	7334
0m			5250*	5250*	8600	4710	5550	3210			3830*	2570	7122
- 1.5m (- 4.11ft)	5940*	5940*	10670*	8590	8560	4680	5530	3190			4660*	2860	6562
- 3.0m (- 9.10ft)			10810*	8750	7650*	4760					5830*	3630	5548
- 4.5m (- 14.9ft)													

LIFT CAPACITIES – Dipper Length: 2.70m, 5.15m Monoboom, Tracks: 500mm, No bucket.

JS I90 NLC MONO

Reach	1.5m (4ft 11in)		3m (9ft 10in)		4.5m (14ft 9in)		6m (19ft 8in)		7.5m (24ft 7in)		Capacity at Max Reach		
											kg	kg	mm
Load Point Ht.	kg	kg	kg	kg	kg	kg	kg	kg	kg	kg	kg	kg	mm
7.5m (24.7ft)											3910*	2910*	5120
6.0m (19.8ft)							3910*	3690			2590*	2590*	6445
4.5m (14.9ft)					4990*	4990*	4630*	3620			2490*	2490*	7227
3.0m (9.10ft)			9550*	9540	6360*	5240	5220*	3470	3280*	2500	2530*	2420	7637
1.5m (4.11ft)			5180*	5180*	7780*	4890	5670	3310	4080*	2430	2680*	2330	7735
0m			6460*	6460*	8570	4680	5530	3200	3270*	2390	2980*	2370	7534
- 1.5m (- 4.11ft)	5810*	5810*	10130*	8410	8490	4610	5480	3150			3570*	2600	7008
- 3.0m (- 9.10ft)	9840*	9840*	11570*	8550	8050*	4660	5550	3210			4890*	3170	6070
- 4.5m (- 14.9ft)			8490*	8490*							5610*	4960	4463

LIFT CAPACITIES – Dipper Length: 3.05m, 5.15m Monoboom, Tracks: 500mm, No bucket.

JS I90 NLC MONO

Reach	1.5m (4ft 11in)		3m (9ft 10in)		4.5m (14ft 9in)		6m (19ft 8in)		7.5m (24ft 7in)		Capacity at Max Reach		
											kg	kg	mm
Load Point Ht.	kg	kg	kg	kg	kg	kg	kg	kg	kg	kg	kg	kg	mm
7.5m (24.7ft)											2430*	2430*	5581
6.0m (19.8ft)							3770*	3690			2180*	2180*	6816
4.5m (14.9ft)							4310*	3610	2360*	2360*	2110*	2110*	7559
3.0m (9.10ft)			8530*	8530*	5920*	5280	4930*	3470	3720*	2470	2140*	2140*	7951
1.5m (4.11ft)			7030*	7030*	7440*	4920	5660	3300	4060	2400	2270*	2160	8045
0m			6820*	6820*	8460*	4680	5510	3170	3990	2340	2520*	2200	7853
- 1.5m (- 4.11ft)	5390*	5390*	9600*	8380	8460	4580	5440	3110			2990*	2390	7350
- 3.0m (- 9.10ft)	8770*	8770*	12070*	8480	8260*	4600	5470	3130			3980*	2860	6463
- 4.5m (- 14.9ft)			9460*	8750	6420*	4770					5510*	4170	4987

Lift capacity front and rear.

Lift capacity full circle.

Notes:

1. For lifting capacity including bucket, subtract total weight of bucket or bucket and quickhitch from above values.
2. Lifting capacities are based on ISO 10567, that is: 75% of minimum tipping load or 87% of hydraulic lift capacity, whichever is the less. Lifting capacities marked* are based on hydraulic capacity.
3. Lift capacities assume that the machine is on firm, level ground.
4. Lift capacities may be limited by local regulations. Please refer to your dealer.



JCB TRACKED EXCAVATOR | JS I90 NLC/LC



LIFT CAPACITIES – Dipper Length: 2.25m, 5.15m Monoboom, Trackshoes: 700mm, No bucket.

JS I90 LC MONO

Reach	1.5m (4ft 11in)		3m (9ft 10in)		4.5m (14ft 9in)		6m (19ft 8in)		7.5m (24ft 7in)		Capacity at Max Reach		
											kg	kg	mm
Load Point Ht.	kg	kg	kg	kg	kg	kg	kg	kg	kg	kg	kg	kg	mm
7.5m (24.7ft)											3900*	3900*	4484
6.0m (19.8ft)											3350*	3350*	5956
4.5m (14.9ft)					5520*	5520*	5000*	3990			3220*	3200*	6795
3.0m (9.10ft)					6880*	5820	5530*	3860			3230*	2940	7230
1.5m (4.11ft)					8190*	5520	5830	3730			3420*	2820	7334
0m			5250*	5250*	8830*	5360	5730	3630			3830*	2900	7122
- 1.5m (- 4.11ft)	5940*	5940*	10670*	9970	8710*	5330	5710	3610			4660*	3230	6562
- 3.0m (- 9.10ft)			10810*	10130	7650*	5410					5830*	4100	5548
- 4.5m (- 14.9ft)													

LIFT CAPACITIES – Dipper Length: 2.70m, 5.15m Monoboom, Trackshoes: 700mm, No bucket.

JS I90 LC MONO

Reach	1.5m (4ft 11in)		3m (9ft 10in)		4.5m (14ft 9in)		6m (19ft 8in)		7.5m (24ft 7in)		Capacity at Max Reach		
											kg	kg	mm
Load Point Ht.	kg	kg	kg	kg	kg	kg	kg	kg	kg	kg	kg	kg	mm
7.5m (24.7ft)											2910*	2910*	5120
6.0m (19.8ft)							3910*	3910*			2590*	2590*	6445
4.5m (14.9ft)					4990*	4990*	4630*	4050			2490*	2490*	7227
3.0m (9.10ft)			9550*	9550*	6360*	5900	5220*	3900	3280*	2810	2530*	2530*	7637
1.5m (4.11ft)			5180*	5180*	7780*	5550	5850	3740	4080*	2740	2680*	2620	7735
0m			6460*	6460*	8640*	5330	5710	3620	3270*	2700	2980*	2680	7354
- 1.5m (- 4.11ft)	5810*	5810*	10130*	9780	8760	5260	5660	3570			3570*	2940	7008
- 3.0m (- 9.10ft)	9840*	9840*	11570*	9930	8050*	5310	5720*	3630			4890*	3580	6070
- 4.5m (- 14.9ft)			8490*	8490*							5610*	5610*	4463

LIFT CAPACITIES – Dipper Length: 3.05m, 5.15m Monoboom, Trackshoes: 700mm, No bucket.

JS I90 LC MONO

Reach	1.5m (4ft 11in)		3m (9ft 10in)		4.5m (14ft 9in)		6m (19ft 8in)		7.5m (24ft 7in)		Capacity at Max Reach		
											kg	kg	mm
Load Point Ht.	kg	kg	kg	kg	kg	kg	kg	kg	kg	kg	kg	kg	mm
7.5m (24.7ft)											2430*	2430*	5581
6.0m (19.8ft)							3770*	3770*			2180*	2180*	6816
4.5m (14.9ft)							4310*	4040	2360*	2360*	2110*	2110*	7559
3.0m (9.10ft)			8530*	8530*	5920*	5920*	4930*	3890	3720*	2780	2140*	2140*	7951
1.5m (4.11ft)			7030*	7030*	7440*	5580	5670*	3720	4190	2710	2270*	2270*	8045
0m			6820*	6820*	8460*	5330	5690	3590	4130	2650	2520*	2490	7853
- 1.5m (- 4.11ft)	5390*	5390*	9600*	9600*	8740	5230	5620	3530			2990*	2710	7350
- 3.0m (- 9.10ft)	8770*	8770*	12070*	9860	8260*	5250	5650	3550			3980*	3240	6463
- 4.5m (- 14.9ft)			9460*	9460*	6420*	5420					5510*	4720	4987



Lift capacity front and rear.



Lift capacity full circle.

Notes:

1. For lifting capacity including bucket, subtract total weight of bucket or bucket and quickhitch from above values.
2. Lifting capacities are based on ISO 10567, that is: 75% of minimum tipping load or 87% of hydraulic lift capacity, whichever is the less. Lifting capacities marked* are based on hydraulic capacity.
3. Lift capacities assume that the machine is on firm, level ground.
4. Lift capacities may be limited by local regulations. Please refer to your dealer.













JCB TRACKED EXCAVATOR | JS I90 NLC/LC













LIFT CAPACITIES – Dipper Length: 2.25m, 5.35m T.A.B., Trackshoes: 500mm, No bucket.

JS I90 NLC T.A.B.

Reach	3m (9ft 10in)		4.5m (14ft 9in)		6m (19ft 8in)		7.5m (24ft 7in)		Capacity at Max Reach		
											mm
Load Point Ht.	kg	kg	kg	kg	kg	kg	kg	kg	kg	kg	mm
9.0m (29.5ft)									7350*	7350*	2181
7.5m (24.7ft)	5950*	5950*	5790*	5610					4190*	4190*	4997
6.0m (19.8ft)	5040*	5040*	5840*	5620	5210*	3530			3520*	3180	6349
4.5m (14.9ft)	8330*	8330*	7140*	5370	5900	3470			3270*	2610	7141
3.0m (9.10ft)			8350*	4980	5720	3320	3870*	2370	3200*	2340	7556
1.5m (4.11ft)			8610	4650	5550	3170	4010	2330	3290*	2260	7655
0m			8200*	4500	5440	3070			3530*	2330	7452
- 1.5m (- 4.11ft)	7550*	7550*	6820*	4500	5090*	3060			3600*	2590	6920
- 3.0m (- 9.10ft)											











LIFT CAPACITIES – Dipper Length: 2.70m, 5.35m T.A.B., Trackshoes: 500mm, No bucket.

JS I90 NLC T.A.B.

Reach	3m (9ft 10in)		4.5m (14ft 9in)		6m (19ft 8in)		7.5m (24ft 7in)		Capacity at Max Reach		
											mm
Load Point Ht.	kg	kg	kg	kg	kg	kg	kg	kg	kg	kg	mm
9.0m (29.5ft)	5450*	5450*							4390*	4390*	3428
7.5m (24.7ft)			4870*	4870*					3100*	3100*	5640
6.0m (19.8ft)			4730*	4730*	4660*	3630			2700*	2700*	6864
4.5m (14.9ft)	5160*	5160*	5540*	5490	5380*	3530	3210*	2450	2540*	2390	7602
3.0m (9.10ft)			8050*	5070	5770	3360	4100	2410	2510*	2170	7992
1.5m (4.11ft)			8640*	4680	5570	3180	4020	2330	2580*	2090	8086
0m			8390*	4460	5420	3050	3960	2280	2760*	2140	7894
- 1.5m (- 4.11ft)	7490*	7490*	7300*	4410	5380	3010			3130*	2340	7394
- 3.0m (- 9.10ft)			5260*	4500	3660*	3090			3190*	2920	6289

LIFT CAPACITIES – Dipper Length: 3.05m, 5.35m T.A.B., Trackshoes: 500mm, No bucket.

JS I90 NLC T.A.B.

Reach	3m (9ft 10in)		4.5m (14ft 9in)		6m (19ft 8in)		7.5m (24ft 7in)		Capacity at Max Reach		
											mm
Load Point Ht.	kg	kg	kg	kg	kg	kg	kg	kg	kg	kg	mm
9.0m (29.5ft)	4950*	4950*							3420*	3420*	4152
7.5m (24.7ft)			4230*	4230*	3000*	3000*			2570*	2570*	6102
6.0m (19.8ft)			4010*	4010*	4150*	3640			2270*	2270*	7247
4.5m (14.9ft)	3880*	3880*	4560*	4560*	4660*	3540	3660*	2450	2140*	2140*	7949
3.0m (9.10ft)			7770*	5130	5780	3360	4090	2390	2120*	2000	8322
1.5m (4.11ft)			8520*	4710	5560	3170	3990	2300	2180*	1930	8413
0m	4230*	4230*	8400	4460	5400	3030	3920	2230	2330*	1970	8229
- 1.5m (- 4.11ft)	7140*	7140*	7600*	4380	5330	2970	3910	2220	2640*	2150	7750
- 3.0m (- 9.10ft)	7240*	7240*	5800*	4430	4190*	3010			2850*	2560	6867



Lift capacity front and rear.



Lift capacity full circle.

Notes:

1. For lifting capacity including bucket, subtract total weight of bucket or bucket and quickhitch from above values.
2. Lifting capacities are based on ISO 10567, that is: 75% of minimum tipping load or 87% of hydraulic lift capacity, whichever is the less. Lifting capacities marked* are based on hydraulic capacity.
3. Lift capacities assume that the machine is on firm, level ground.
4. Lift capacities may be limited by local regulations. Please refer to your dealer.



JCB TRACKED EXCAVATOR | JS I90 NLC/LC



LIFT CAPACITIES – Dipper Length: 2.25m, 5.35m T.A.B., Trackshoes: 700mm, No bucket.

JS I90 LC T.A.B.

Reach	3m (9ft 10in)		4.5m (14ft 9in)		6m (19ft 8in)		7.5m (24ft 7in)		Capacity at Max Reach		
Load Point Ht.	kg	kg	kg	kg	kg	kg	kg	kg	kg	kg	mm
9.0m (29.5ft)									7350*	7350*	2181
7.5m (24.7ft)	5950*	5950*	5790*	5790*					4190*	4190*	4997
6.0m (19.8ft)	5040*	5040*	5840*	5840*	5210*	3970			3520*	3520*	6349
4.5m (14.9ft)	8330*	8330*	7140*	6050	6060*	3900			3270*	2940	7141
3.0m (9.10ft)			8350*	5650	5900	3750	3870*	2690	3200*	2660	7556
1.5m (4.11ft)			8730*	5310	5730	3590	4140	2640	3290*	2570	7655
0m			8200*	5160	5620	3500			3530*	2640	7452
- 1.5m (- 4.11ft)	7550*	7550*	6820*	5150	5090*	3490			3600*	2930	6920
- 3.0m (- 9.10ft)											

LIFT CAPACITIES – Dipper Length: 2.70m, 5.35m T.A.B., Trackshoes: 700mm, No bucket.

JS I90 LC T.A.B.

Reach	3m (9ft 10in)		4.5m (14ft 9in)		6m (19ft 8in)		7.5m (24ft 7in)		Capacity at Max Reach		
Load Point Ht.	kg	kg	kg	kg	kg	kg	kg	kg	kg	kg	mm
9.0m (29.5ft)	5450*	5450*							4390*	4390*	3428
7.5m (24.7ft)			4870*	4870*					3100*	3100*	5640
6.0m (19.8ft)			4730*	4730*	4660*	4070			2700*	2700*	6864
4.5m (14.9ft)	5160*	5160*	5540*	5540*	5380*	3970	3210*	2770	2540*	2540*	7602
3.0m (9.10ft)			8050*	5740	5950	3790	4240	2720	2510*	2460	7992
1.5m (4.11ft)			8640*	5340	5750	3600	4150	2640	2580*	2370	8086
0m			8400*	5120	5600	3480	4100	2590	2760*	2430	7894
- 1.5m (- 4.11ft)	7490*	7490*	7300*	5070	5470*	3440			3130*	2660	7394
- 3.0m (- 9.10ft)			5260*	5150	3660*	3510			3190*	3190*	6289

LIFT CAPACITIES – Dipper Length: 3.05m, 5.35m T.A.B., Trackshoes: 700mm, No bucket.

JS I90 LC T.A.B.

Reach	3m (9ft 10in)		4.5m (14ft 9in)		6m (19ft 8in)		7.5m (24ft 7in)		Capacity at Max Reach		
Load Point Ht.	kg	kg	kg	kg	kg	kg	kg	kg	kg	kg	mm
9.0m (29.5ft)	4950*	4950*							3420*	3420*	4152
7.5m (24.7ft)			4230*	4230*	3000*	3000*			2570*	2570*	6102
6.0m (19.8ft)			4010*	4010*	4150*	4080			2270*	2270*	7247
4.5m (14.9ft)	3880*	3880*	4560*	4560*	4660*	3970	3660*	2770	2140*	2140*	7949
3.0m (9.10ft)			7770*	5800	5960	3790	4220	2700	2120*	2120*	8322
1.5m (4.11ft)			8520*	5380	5740	3600	4120	2610	2180*	2180*	8413
0m	4230*	4230*	8505*	5120	5580	3450	4050	2550	2330*	2250	8229
- 1.5m (- 4.11ft)	7140*	7140*	7600*	5030	5510	3390	3940*	2540	2640*	2450	7750
- 3.0m (- 9.10ft)	7240*	7240*	5800*	5090	4190*	3430			2850*	2850*	6867



Lift capacity front and rear.



Lift capacity full circle.

Notes:

1. For lifting capacity including bucket, subtract total weight of bucket or bucket and quickhitch from above values.
2. Lifting capacities are based on ISO 10567, that is: 75% of minimum tipping load or 87% of hydraulic lift capacity, whichever is the less. Lifting capacities marked* are based on hydraulic capacity.
3. Lift capacities assume that the machine is on firm, level ground.
4. Lift capacities may be limited by local regulations. Please refer to your dealer.



A GLOBAL COMMITMENT TO QUALITY

JCB's total commitment to its products and customers has helped it grow from a one-man business into Britain's largest privately owned manufacturer of backhoe loaders, crawler excavators, wheeled excavators, telescopic handlers, wheeled loaders, dump trucks, rough terrain fork lifts, industrial fork lifts, mini/midi excavators, skid steer loaders and tractors.

By making constant and massive investments in the latest production technology, the JCB factories have become some of the most advanced in Europe.

By leading the field in innovative research and design, extensive testing and stringent quality control, JCB machines have become renowned all over the world for performance, value and reliability.

And with a global sales and service network of over 400 distributors and agents, the company exports over 70% of its production to all five continents.

Through setting the standards by which others are judged, JCB has become one of Britain's most impressive success stories.

