

MAX. PAYLOAD: 2600kg (5730lb) MAX. LIFT HEIGHT: 5.6m (18ft 4in)

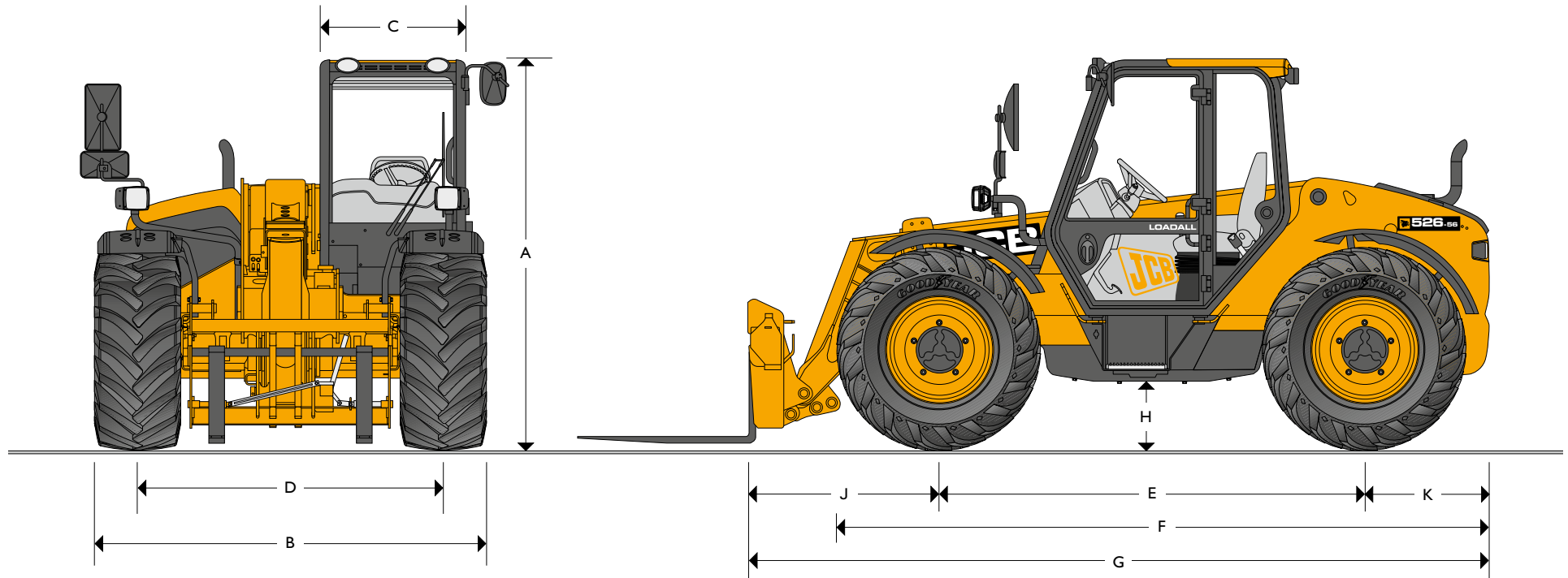

STATIC DIMENSIONS

	m (ft-in)		m (ft-in)
A Overall height	2.40 (7-11)	K Rear wheel centre to rear face	0.78 (2-7)
B Overall width (over tyres)*	2.29 (7-6)	Carriage roll back angle	degrees 38.5
C Inside width of cab	0.88 (2-11)	Carriage dump angle	degrees 33
D Front track	1.81 (6.0)	Outside turn radius (over tyres) 4WS	3.58 (11-9)
E Wheelbase	2.66 (8-9)	Weight	kg (lb) 6270 (13823)
F Overall length to front tyres	4.07 (13-4)	Tyres	460/70xR24
G Overall length to front carriage	4.66 (15-4)		
H Ground clearance	0.44 (1-5)		
J Front wheel centre to carriage	1.20 (3-11)		

* Dependant upon tyre specified.

LIFT PERFORMANCE

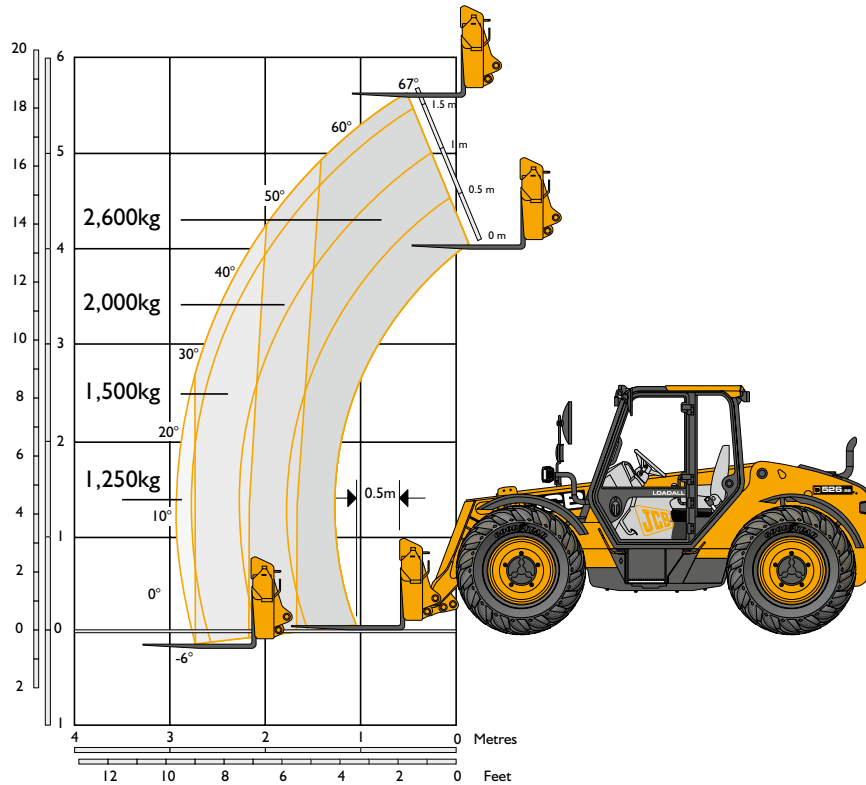

LIFT PERFORMANCE

Maximum lift capacity	kg (lb)	2600 (5730)
Lift capacity to full height	kg (lb)	2600 (5730)
Lift capacity at full reach	kg (lb)	1250 (2755)
Lift height	m (ft-in)	5.60 (18-4)
Reach at maximum lift height	m (ft-in)	0.53 (1-9)
Maximum forward reach	m (ft-in)	2.95 (9-8)
Reach with 1 tonne load	m (ft-in)	2.95 (9-8)
Placing height	m (ft-in)	4.87 (16-0)

Complies with stability test EN 1459 Annex B.

ENGINE

Latest technology and advanced design provides low fuel consumption, reduced noise, high torque and power output, total reliability and minimal maintenance. Two-stage, dry type air filter with primary and safety elements. Territory dependent.

		Stage II	Stage III	Stage III
Model		Agri	Agri	Agri Plus
Manufacturer		JCB	JCB	JCB
Displacement	ltr (in ³)	4.4 (269)	4.4 (269)	4.4 (269)
No. of cylinders		4	4	4
Bore size	mm (in)	103 (4.05)	103 (4.05)	103 (4.05)
Stroke	mm (in)	132 (5)	132 (5)	132 (5)
Aspiration		Turbo	Turbocharged cooled	Turbocharged cooled
Power rating				
Power @ 2200rpm	kW (HP)	74.2 (100)	74.2 (100)	85.0 (114)
Torque rating				
Torque @ 1300rpm	Nm (lb ft)	425 (313)	440 (324)	440 (324)

TRANSMISSION

Agri: JCB Synchro Shuttle transmission incorporating torque converter, bevel box, reversing shuttle and 4-speed synchromesh gearbox in one resiliently mounted unit. Steering column mounted switch incorporating directional control. Transmission disconnect on gear lever and loader lever.

Agri Plus: JCB powershift transmission incorporating torque converter, bevel box and a 4 speed powershift gearbox in one resiliently mounted unit. A combined steering column mounted switch incorporating directional control and 4 forward and 4 reverse powershift gears. Transmission disconnect on loader lever.

Travel speed: 33kph (40kph optional only with powershift)

Front and rear drive axles: JCB epicyclic hub reduction drive/steer axles with Max-Trac torque proportioning differentials. 2/4 wheel drive disconnect.

BRAKES

Service brakes – Hydraulically operated self-adjusting, oil-immersed in-board multi-disc type on front axle.

Parking brake – Hand operated disc brake on output of gearbox.

BOOM AND CARRIAGE

Boom is manufactured from high tensile steel. Low maintenance, hard wearing pads.

JCB tool carrier/QFit parallel lift carriage with mechanical pin locking.

One boom and auxiliary hydraulic service fitted as standard.

SAFETY CHECK VALVES

Fitted to carriage tilt, telescopic and boom lift rams.

SERVICE CAPACITIES

Fuel tank	litres (UK gal)	120 (26.4)
Hydraulic tank	litres (UK gal)	116 (25.5)
Coolant	litres (UK gal)	22 (4.4)

HYDRAULICS

Two stage gear pump, fitted with suction strainer and filter. One boom end auxiliary hydraulic service fitted as standard.

Operating system pressure	bar (psi)	260 (3770)
Flow at system pressure @ 2200rpm	ltr/min (gal/min)	80 (17.6)
Hydraulic Cycle Times	Seconds	
Boom raise		5.2
Boom lower		3.8
Extend		4.5
Retract		2.4
Bucket dump		2.6
Bucket crowd		3.1

ELECTRICS

12v negative earth. 95 AH heavy duty battery. 95 amp alternator. Full road lighting. Reversing light. Direction indicators. Hazard warning. Reverse alarm.

CAB

Quiet, safe and comfortable cab conforms to ROPS ISO 3471 and FOPS ISO 3449. Tinted glass all round, with laminated roof screen. Roof bars, front screen and roof screen wipers and heater/screen demister. Rear opening window with wash/wipe. Audio-visual warning system for coolant temperature, engine oil pressure, air-cleaner, battery charge, transmission oil temperature and pressure, water in fuel, low water level. Hourmeter, road speed indicator, fuel gauge, engine temperature, clock and inclinometer. Adjustable suspension seat, tilt steer column, park brake, floor mounted throttle and brake pedals.

Hydraulic controls:

Agri: Multi lever direct acting hydraulic control levers with joystick control of lift and crowd.

Agri Plus: Single lever oil pilot servo joystick, incorporating forward/neutral/reverse, transmission disconnect, with progressive extend/retract and auxiliary incorporating constant flow facility.

Load Moment Indicator:

Automatic eye level audio-visual load moment indicator warning system receiving a signal from a load sensor on the rear axle. This system continuously monitors the machine's forward stability and leaves the operator in control at all times.

STEERING

Hydrostatic power steering with power track rods on both axles.

Three steer mode options: front wheel steer; all wheel steer; crab steer; operated from in the cab by a selection lever.

Option: In cab selector switch with Auto Align.

OPTIONS AND ACCESSORIES

Options: Front and rear working lights, rotating flashing beacon, fire extinguisher, front screen guard, air conditioning, radial tyres, 2 boom end auxiliary services, sunblind, radio kit, carriage hydraulic locking, limited slip differential in front axle, smoothride system, air suspension seat, reversing fan, 2-speed front wash/wiper, powershift transmission, oil pilot single lever joystick with proportional control, towing facility with trailer lighting package, carriage options available – contact your local dealer.

Attachments: available with tool carrier or Q-fit style carriage. Contact your local dealer for details of the comprehensive range.

A GLOBAL COMMITMENT TO QUALITY

JCB's total commitment to its products and customers has helped it grow from a one-man business into Britain's largest privately owned manufacturer of backhoe loaders, crawler excavators, wheeled excavators, telescopic handlers, wheeled loaders, dump trucks, rough terrain fork lifts, industrial fork lifts, mini/midi excavators, skid steer loaders, tractors and compaction equipment.

By making constant and massive investments in the latest production technology, the JCB factories have become some of the most advanced in the world.

By leading the field in innovative research and design, extensive testing and stringent quality control, JCB machines have become renowned all over the world for performance, value and reliability.

And with a global sales and service network of more than 650 dealers and agents, we aim to deliver the best customer support in the industry.

Through setting the standards by which others are judged, JCB has become one of the world's most impressive success stories.

